

# THUMBIES

- CONVERTS BAR END AND DOWN TUBE SHIFTERS TO THUMB SHIFTERS
- INCREDIBLY PRECISE & INTUITIVE SHIFTING

paulcomp.com

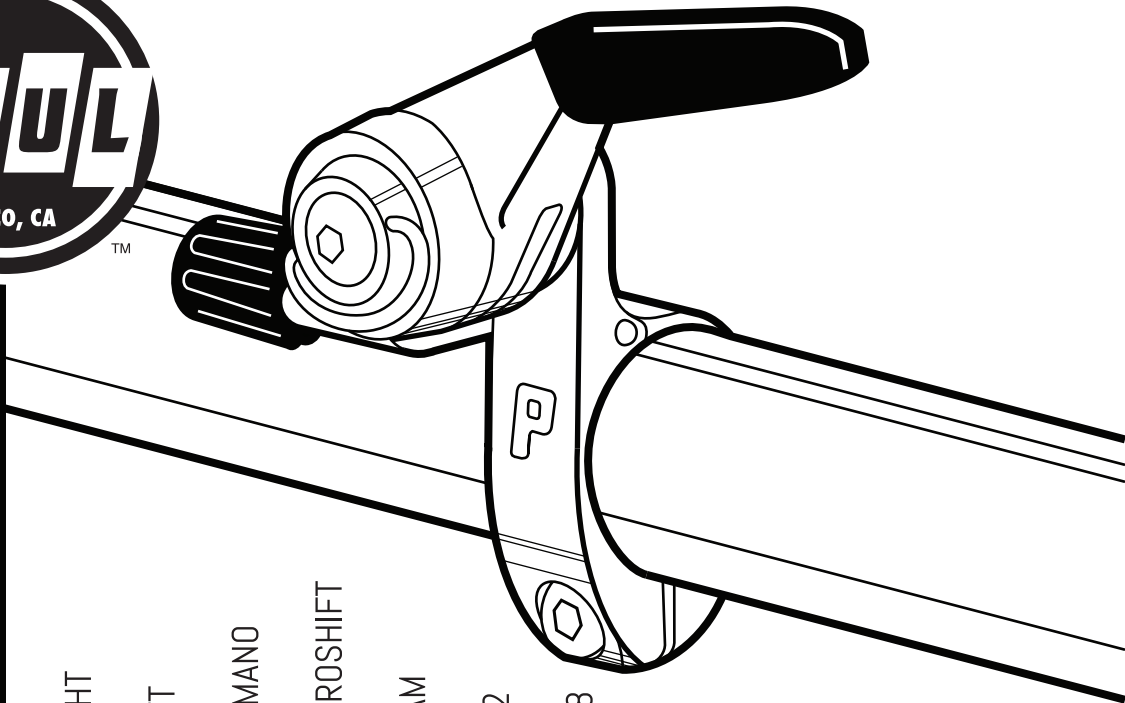

RIGHT

LEFT

SHIMANO

MICROSHIFT

SRAM

22.2

31.8



NICE PARTS SINCE 1989

# ATTENTION : READ CAREFULLY

---

## INSTALLATION:

1. Mount Thumbie on the bar in the approximate position you want.
  2. Remove the bar end shifter from its bar end bracket. Save the screw.
  3. Mount shifter on Thumbie and install using the screw that came with the shifters.
  4. Rotate the shifter through all its range to make sure the alignment is correct.
  5. Install cables and housing and make sure shifters are in position. Tighten all screws and go for a test ride.
- 

♻️ PLEASE RECYCLE



paulcomp.com



Email: [info@paulcomp.com](mailto:info@paulcomp.com)  
Phone: 530-345-4371  
11204 Midway  
Chico, California 95928