



**THE COMPLETE GUIDE
TO THE LAWWILL-KNIGHT
PRO CRUISER**



MANUFACTURERS OF SPECIALIZED BICYCLES
105 Rock Hill Drive
Tiburon, CA 94920
(415) 435-5931

26" PRO-CRUISER



(Street)

COMPONENT LIST

Frame: Chrome-moly 20 degree rake

Goose Neck: Wald

Handle Bars: chrome-moly

Seat Post: chrome-moly 15 long

Front Fork: Tange cro-mo 115/16
offset

Pedals: Shimano MX

Free Wheel: 20T single speed

NOTE: 5,10, & 15 speed kits available

Chain: Unaglide 600

Cranks: Alloy Tourney MX 44T

Seat: Mesinger or Brooks B-72

Wheel rim: UKAI alloy

Spokes: Stainless Steel

Brakes: Mayfac cantilever rear only

Tires: IRC RACER X-1 26x2.125

Seat Post Clamp: Suntour quick release

COLOR: Electrostatic Black, Red & Blue

Suggested Retail Mesinger Seat....\$495.00

Suggested Retail Brooks B-72 Seat..\$505.00



MANUFACTURERS OF SPECIALIZED BICYCLES
105 Rock Hill Drive
Tiburon, CA 94920
(415) 435-5931

26" PRO-CRUISER FRAME SPECIFICATIONS

(STREET)

Manufactured from a combination of 5/8", 3/4", and 1 1/4" .035 wall thickness 4130 chrome-moly tubing and heli-arc welded, this frame weighs only 5 1/2' lbs. It uses a 1010 bottom bracket shell and headtube, and comes with a derailleur tab for Shimano and Suntour derailleurs welded on.

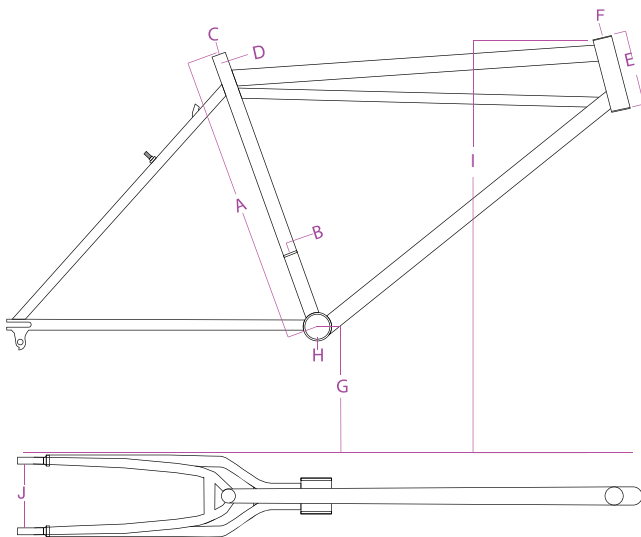

- A. Seat Tube Length/Frame Size
(Bottom bracket center to top of seat tube).....18 3/4"
- B. Seat Tube Diameter
(Front Derailleur Fit).....1 1/4"
- C. Required Seat Post Size.....1 1/16"
- D. Required Seat Clamp Size.....1 1/8"
- E. Head Tube Length.....5"
- F. Headset Tytpe.....Shimano MX2
- G. Bottom Bracket Height
(To center of bottom bracket).12 1/4"
- H. Bottom Braket Type.....2" Press in Type
- I. Top Tube Height.....highest 31 1/4"
.....lowest 28"
- J. Rear Dropout Inside Width.....127mm(5")
(A 7" Rear Axle must be used because of the wide dropout design)
- K. Wheel Base.....44"
 Rake.....20 1/2 degrees
- L. Weight.....5 1/2 lbs

Suggested Retail: (unpainted).....\$195.00
 (painted).....\$205.00
 (with Mayfac weld on, unpainted).....\$205.00
 (with Mayfac weld on, painted).....\$205.00

Suggested Retail: (chrome).....\$30.95



MANUFACTURERS OF SPECIALIZED BICYCLES
105 Rock Hill Drive
Tiburon, CA 94920
(415) 435-5931

LAWWILL-KNIGHT
PRO CRUISER (STREET)





MANUFACTURERS OF SPECIALIZED BICYCLES
105 Rock Hill Drive
Tiburon, CA 94920
(415) 435-5931

26" PRO-CRUISER



COMPONENT LIST (Mountain Bike)

Frame: Chrome-moly 22 1/2 degree rake
Goose Neck: Chrome-moly hand crafted
Handle Bars: chrome-moly
Seat Post: chrome-moly 15 long
Front Fork: Tange cro-mo 1 1/2 offset
Pedals: Shimano MX
Free Wheel: 14, 17, 22, 28, & 34 teeth
NOTE: 10 & 15 speed kits available
Derailleur: Shimano 600
Thumb Shifter
Chain: Unaglide 600

Cranks: Alloy Tourney MX 44T
Seat: Mesinger or Brooks B-72
Wheel rim: UKAI alloy
Spokes: Stainless Steel
Brakes: Strumey-Archer drum Front & Rear
Tires: IRC RACER X-1 26x2.125
Seat Post Clamp: Suntour quick release

COLOR: Electrostatic Black, Red & Blue

Suggested Retail Mesinger Seat....\$595.00
Suggested Retail Brooks B-72 Seat..\$605.00



MANUFACTURERS OF SPECIALIZED BICYCLES
105 Rock Hill Drive
Tiburon, CA 94920
(415) 435-5931

26" PRO-CRUISER FRAME SPECIFICATIONS
 (MOUNTAIN BIKE)

Manufactured from a combination of 5/8", 3/4", and 1 1/4" .035 wall thickness 4130 chrome-moly tubing and heli-arc welded, this frame weighs only 5 1/2 lbs. It uses a 1010 bottom bracket shell and headtube, and comes with a derailleur tab for Shimano and Suntour derailleurs welded on.

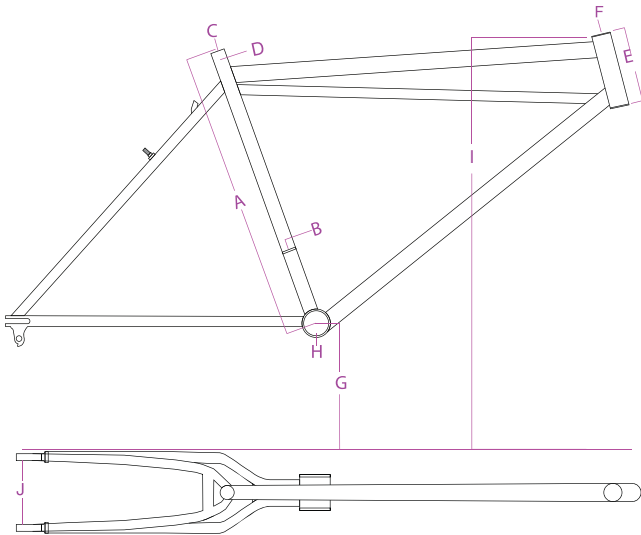

- A. Seat Tube Length/Frame Size....18 3/4"
 (Bottom bracket center to top of seat tube).....18 3/4"
- B. Seat Tube Diameter
 (Front Derailleur Fit).....1 1/4"
- C. Required Seat Post Size.....1 1/16"
- D. Required Seat Clamp Size.....1 1/8"
- E. Head Tube Length.....5"
- F. Headset Tytpe.....Shimano MX2
- G. Bottom Bracket Height
 (To center of bottom bracket). 12 3/8"
- H. Bottom Braket Type...2" Press in Type
- I. Top Tube Height...highest 31"
lowest 29 3/4"
- J. Rear Dropout Inside Width...127mm(5")
 (A 7" Rear Axle must be used because of the wide dropout design)
- K. Wheel Base.....44 3/4"
- L. Weight.....5 1/2 lbs

Suggested Retail:(unpainted).....\$195.00
(painted).....\$205.00

Suggested Retail:(chrome).....\$30.95



MANUFACTURERS OF SPECIALIZED BICYCLES
105 Rock Hill Drive
Tiburon, CA 94920
(415) 435-5931

LAWVILL-KNIGHT
PRO CRUISER (MOUNTAIN)





MANUFACTURERS OF SPECIALIZED BICYCLES
105 Rock Hill Drive
Tiburon, CA 94920
(415) 435-5931

26" PRO-CRUISER COMPONENT LIST

(TRAIL-BLAZER)

FRAME: Chrome-moly tubing and heli-arc welded
rake-69.5 degrees
weight is 5&1/4 lbs

HANDLE BARS/GOOSE NECK: LAWWILL-KNIGHT MOUNTAIN BAR
chrome-moly tubing chrome plated
weight is just under 2 lbs.

SEAT POST: LAPRADE SR 8 long 26.6mm aluminum

SEAT: SELLE ROYAL

SEAT POST BINDER: SUNTOUR Model QR-170 quick release

FRONT FORK: TANGE Model 140 mountain bike

CRANK SET: TAKAGI XT triple 26, 36, & 46 teeth 175mm
sealed bearing bottom bracket

PEDALS: SUNTOUR XC-1 mountain bike pedals model PL-5000

FREE WHEEL: 14, 17, 22, 28, 34 teeth

DERAILLEURS: FRONT, SHIMANO MTB FD-AL-11

REAR, SHIMANO 600

CHAIN: UNAGLIDE 600

WHEELS: UKAI alloy

stainless steel spokes

SHIMANO MOUNTAIN BIKE SEALED BEARING HUBS

BRAKES: NEW POWER-GRIP or MAFAC CANTILEVER

TIRES: IRC RACER X-1 26x2.125



MANUFACTURERS OF SPECIALIZED BICYCLES
105 Rock Hill Drive
Tiburon, CA 94920
(415) 435-5931

26" PRO-CRUISER FRAME SPECIFICATIONS
 (TRAIL-BLAZER)

Manufactured from a combination of 5/8", 3/4", 1&1/8" and 1&1/4" .035 wall thickness 4130 chrome-moly tubing and heli-arc welded, this frame weighs only 5&1/4' lbs. It uses a European type bottom bracket with a triple (26, 36, 46) cotterless crankset. The derailleur tab fits Shimano and Suntour derailleurs. A full set of weld-ons are welded in place.

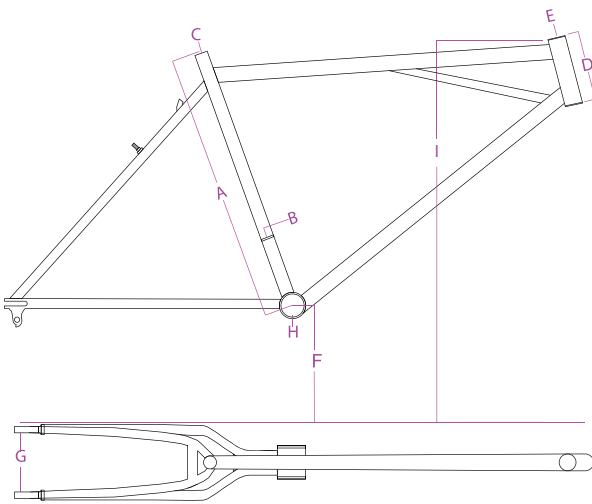

- A. Seat Tube Length/Frame Size....19"
 (Bottom bracket center to top of seat tube).....19"
- B. Seat Tube Diameter
 (Front Derailleur Fit).....1&1/8"
- C. Required Seat Post Size.....26.6mm
- D. Head Tube Length.....5&1/4"
- E. Headset Tytpe.....Shimano MX2
- F. Bottom Bracket Height
 (To center of bottom bracket). 12&1/4"
- G. Rear Dropout Inside Width..127mm(5")
- H. Bottom Bracket Type....Cotterless
- I. Top Tube Height...highest 31"
lowest 29&3/4"

Wheel base.....43-43&1/2
 Rake.....20&1/2 degrees
 Weight.....5&1/4lbs

Suggested Retail: (unpainted)....\$195.00
 (painted).....\$205.00
 (with Power-Grip or Mafac weld ons)
unpainted..\$205.00
painted..\$215.00



MANUFACTURERS OF SPECIALIZED BICYCLES
105 Rock Hill Drive
Tiburon, CA 94920
(415) 435-5931

LAWWILL-KNIGHT
PRO CRUISER (TRAIL-BLAZER)



TRAILMASTER

ALL TERRAIN BICYCLES



PRO-CRUISER Photo: CALIFORNIA TRAVIS

The PRO-CRUISER with drum brakes, 5 Speeds, and chromeoly frame, has been developed by TRAILMASTER & LAWWILL-KNIGHT LTD. to provide the necessary strength, lightness and reliability required for off-road use. The Sturmey-Archer drum brakes supply braking power wet or dry. The Shimano 14x34T Uni-glide freewheel and "600" long arm derailleurs provide a wide gear range. The T.I.G. welded chromeoly frame that ties it all together is built by Terry Knight and has been proven as solid as a rock yet weighs only 5-1/2 lbs. Frame is finished in either electrostatic candy red epoxy paint or nickel plated. A quick-release seatpost allows instant changes in seat height to suit the terrain. Quality and price hard to surpass.

No. PC-5R.....CANDY RED ELECTROSTATIC EPOXY
No. PC-5N.....NICKEL PLATED

PARTS LIST

HANDLEBARS: 4130 Chromemoly
STEM: Redline or Pro-Neck
HEADSET: Tange
BRAKE LEVERS: K&L "Power Lever"
DERAILLEUR CONTROL: Shimano or Suntour
Thumbshifter
SADDLE: Brooks B-72
SEATPOST: 4130 Chromemoly
SEATPOST QUICK-RELEASE: Suntour
CRANK BEARING: Takagi/Shimano
CRANKS: Shimano "600", 44T
PEDALS: KKT, Chromemoly Axle

REAR DERAILLEUR: Shimano "600" Long Arm
Or Suntour V-GT Long Arm
FREEWHEEL: Shimano Uni-Glide 14-34
CHAIN: Shimano Uni Glide
HUBS: Sturmey-Archer Drum Brake
SPOKES: D.T. Stainless Steel 14 Ga./Straight Ga.
RIMS: Ukai 26" x 1.75"
"Box" Aluminum, Gold
TIRES: Carlisle or Uniroyal 26" x 2.125" Knobby
FORK: Tange/Mild Steel Blades
With Chromemoly Steerer Tube
Optional Chromemoly Fork Available
FRAME: (Size: 18-1/2") T.I.G. Welded
4130 Chromemoly

NOTE: All frames use 26" x 2.125 or 26" x 1.75 wheels

PRO-CRUISER

No. 800-PC-U

DEVELOPED BY TRAILMASTER & LAWWILL-KNIGHT LTD.
T.I.G. WELDED 4130 CHROMEOLY TUBING (WITH 1010 BOTTOM BRACKET SHELL AND HEAD TUBE) COMPLETE WITH WELDED-ON REAR DERAILLEUR TAB FOR SHIMANO DERAILLEUR: FITS SUNTOUR AND HURET DUO-PAR ALSO. UNPAINTED

No. 800-PC-R

SAME AS ABOVE BUT WITH ELECTROSTATIC CANDY RED EPOXY PAINT.

No. 800-PC-N

SAME AS ABOVE BUT WITH POLISHED NICKEL PLATING

SPECIFICATIONS:

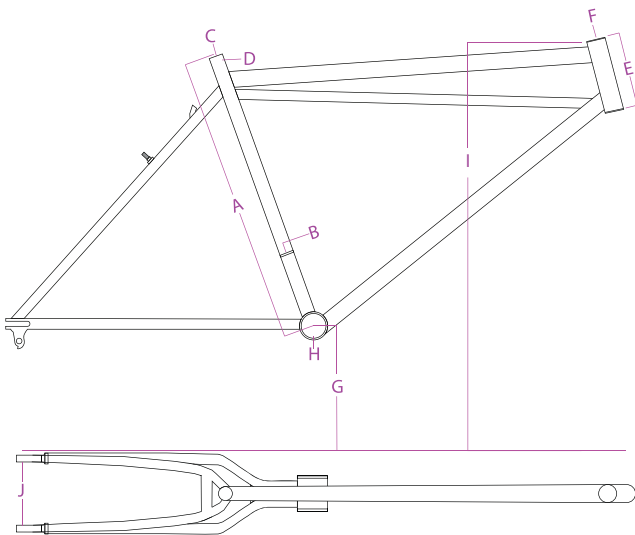

- A. SEAT TUBE LENGTH / FRAME SIZE
(Bottom bracket center to top of seat tube)18 3/4"
- B. SEAT TUBE OUTSIDE DIAMETER
(Bottom bracket center to top of seat tube)1 1/4"
- C. REQUIRED SEAT POST SIZE (O.D.)1-1/16"
- D. SEAT POST CLAMP SIZE REQUIRED1-1/8"
- E. HEAD TUBE LENGTH5"
- F. REQUIRED HEADSET TYPE.....CAT.No.710-TG-0
- G. BOTTOM BRACKET HEIGHT
(To center of bottom bracket)12-3/8"
- H. BOTTOM BRACKET TYPE.....2" PRESS IN CUP TYPE
- I. TOP TUBE HEIGHT
(Measured at highest point).....30 3/4"
- J. INSIDE REAR DROPOUT WIDTH.....127mm(5")
(An extra-long rear axle, e.g. 7", is needed with this frame because of its wide dropouts).
- K. RECOMMENDED FOR: CHROMEOLY, LAGUNA OR TRAILMASTER
- L. WEIGHT (Painted).....5 1/2" lbs

MINIMUM INSEAM SIZE (Crotch to floor: 32")

NOTE:

REAR HUB SHOULD BE SPACED PLUS OR MINUS 1/16" OF "J" DIMENSION TO PREVENT BOWING OF AXLE WHEN AXLE NUTS ARE TIGHTENED



COLORS

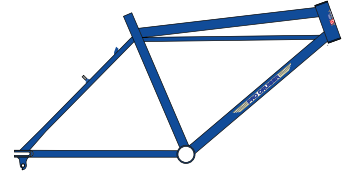
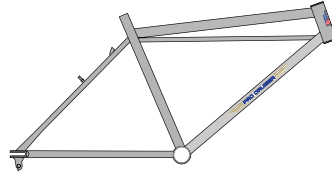
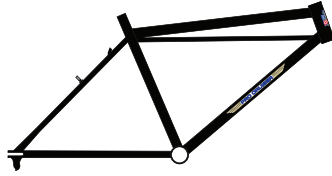
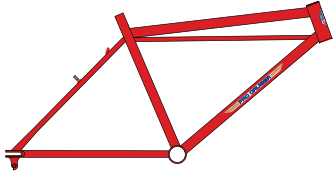

ELECTROSTATIC
CANDY RED

ELECTROSTATIC
BLACK

NICKEL PLATED

BLUE

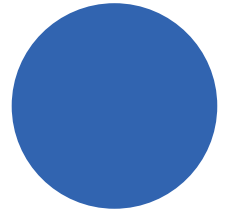
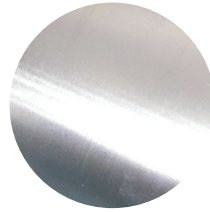
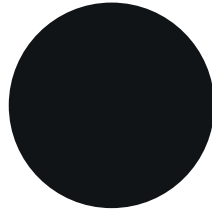
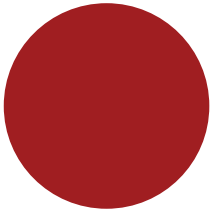



COLORS



Don Koski believes this came out of Cove Shop. They apparently did some of this orange paint and lots of braze ons on the Pro Cruisers.

ORANGE





SERIAL NUMBERS

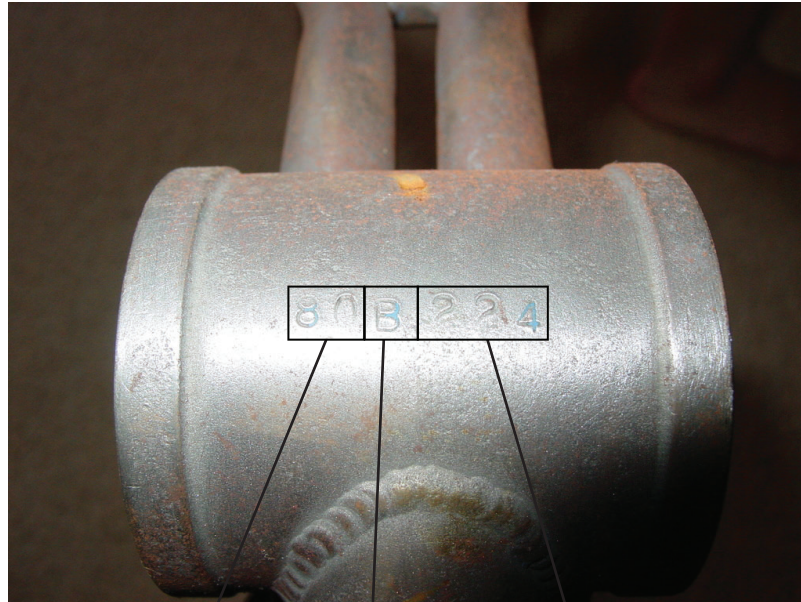

Year		Brake Type	Frame Number		
8	0	B	2	2	4

Production Years					
1977					
1978					
1979					
1980					
1981					

Brake Types					
A	Cantilever				
B	Drum				

Wheel Size					
24"					
26"					



SERIAL NUMBERS

“B”TYPE

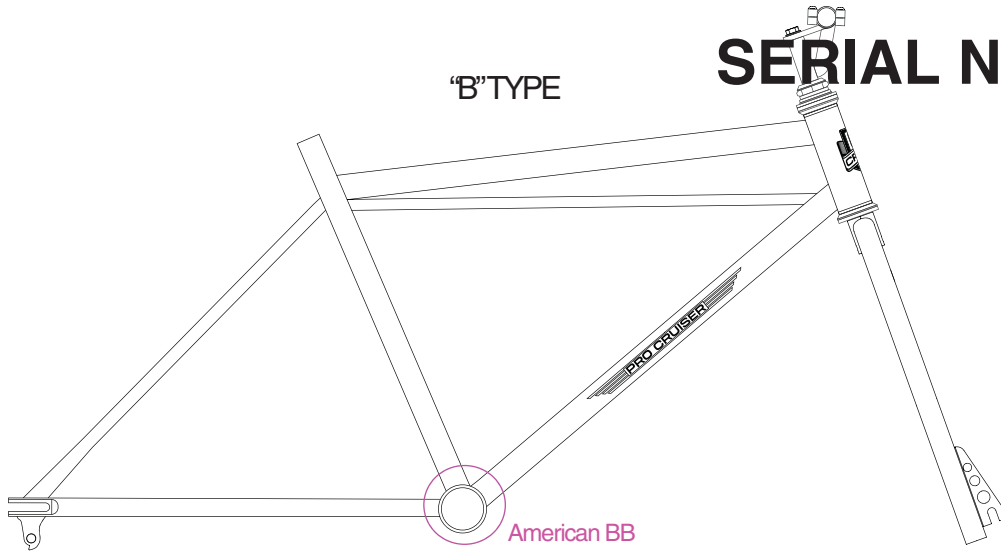

“A”TYPE

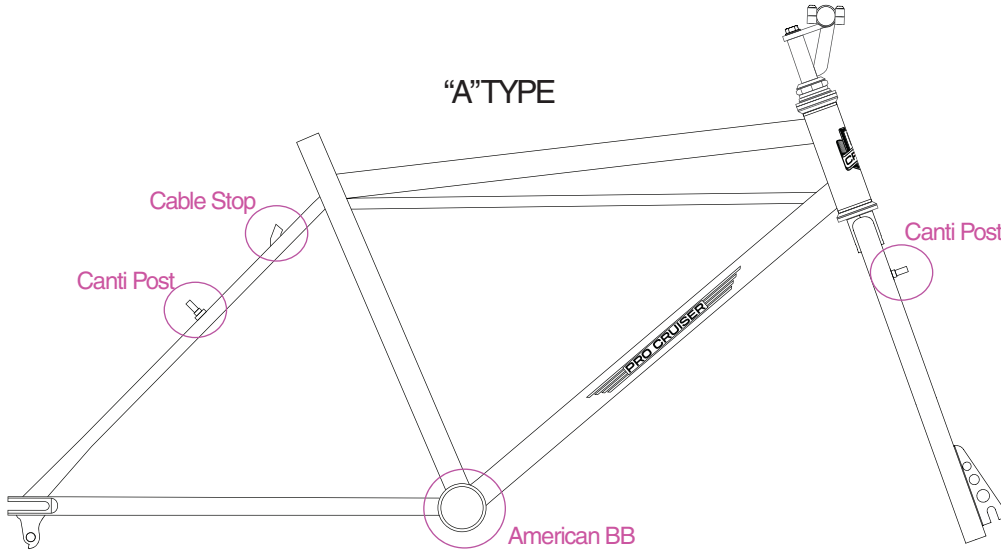

“TRAIL BLAZER”

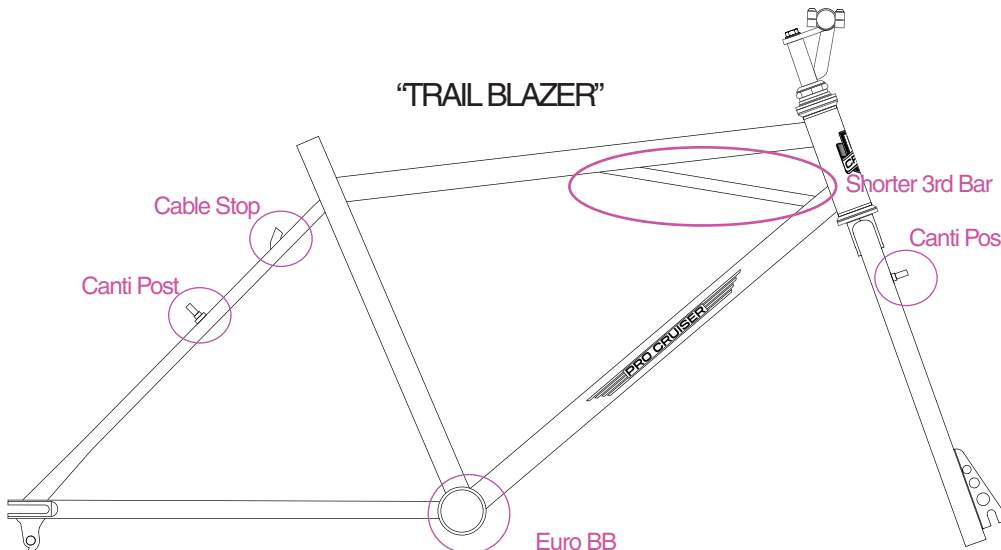

FRAME DECALS

BADGE

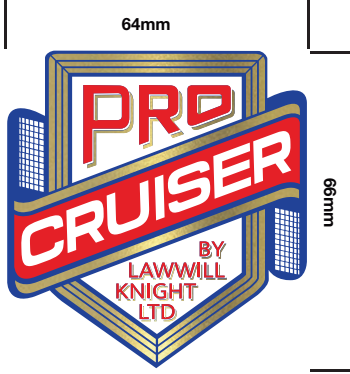

- PANTONE 286C
- PANTONE 186C
- PANTONE METALLIC 8383
- PRINTED ON WHITE

SIDE LOGOS

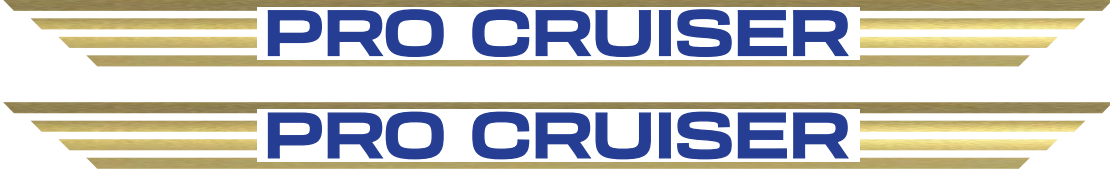

FRAME DETAILS

OEM CABLE STOPS ON PRO CRUISERS
(From Terry Knight Hayward shop)



FRAME DETAILS

NON OEM CABLE STOPS ON PRO CRUISERS



These were the Rear Cable stop

The Cove Bike Shop

Would "weld on" AFTER getting frames
from Lawwill Knight

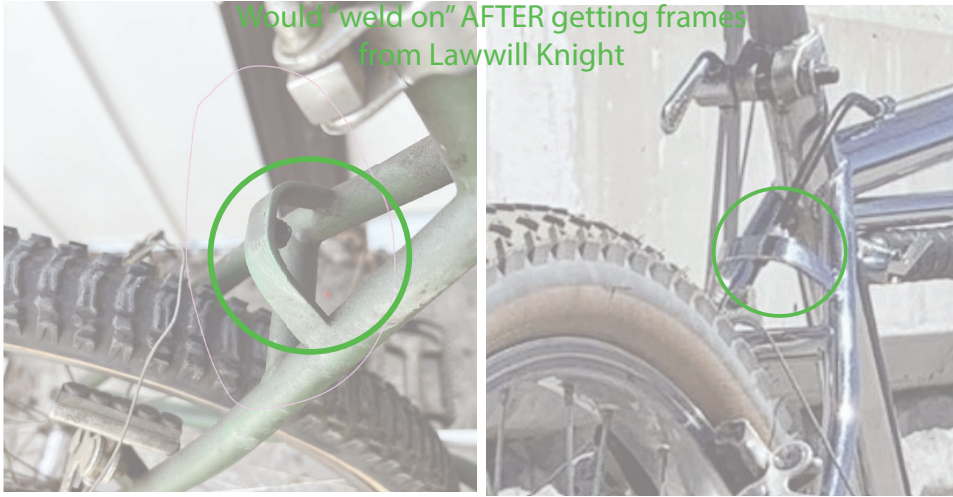

WELD-ONS

The Cove Bike Shop
Offered weld on
upgrades when you
purchased a bike from
there shop



Pump Holder

Rack Mount

Water Bottle Mounts



Drum Brake Mount



Rack Mount

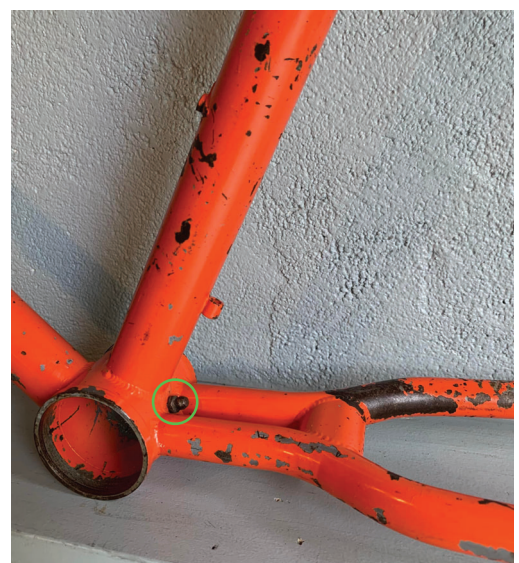

BB zerker fitting



DON KOSKI/TERRY COX



ACTION SHOTS





Compiled by



BIKE PARTS • BIKE RESTORATION • BIKE CUSTOMIZATION

2023 No Copyrights, No permission, No profit, If we know the source we will mention, If we know the rider we will mention, If we made a mistake sorry we are big fans though

PRO CRUISER ORIGIN STORY



Ray Hensley creates Track Master Racing Frames
Mike Konle & Lynn Kasten work for Ray



Mike Konle & Lynn Kasten create Redline in 1971
By 1975 they start to focus on BMX
In 1978 they acquire Champion following death of Doug Schwerma



Doug Schwerma creates Champion Racing frames
By 1975 start offering ultra trick BMX frames
Terry Knight is welder at Champion
Doug Schwerma dies and Terry Knight leaves Champion



Mert Lawwill & Terry Knight consider making BMX frames but Don Koski convinces them to make 26" mountain bike (later called Pro Cruiser)



Terry continued to make dirt track racing frames & swing arms



Koski family gets into bicycle shop business.
By 1974 the brothers start to develop an off-road bicycle fork (hire Cook Bros Racing to make) as well as purpose built off-road bike frame.



In 1972 Cook Bros Racing is born Craig & Gary Cook start making high performance BMX bikes & components. In 1975 Don Koski has Cook Bros build him a 26" 4130 chromoly off road specific fork. By 1978 this fork will be spec'd on Lawwill Pro Cruiser Later becomes one of Cook Bros most successful products

COVE BIKE SHOP - SPIN-OFF BRANDS



COOK BROS RACING - SPIN-OFF BRAND



PRO CRUISER EVOLUTION

1974



In 1974 Matthews Motocross launches motocross inspired 20" BMX bike with a monoshock.

1974



Donny Koski a cyclist & a motorcyclist takes the idea and applies the concept to a 26" off road bicycle platform.

1975



BY 1975 Donny has a NEW 26" prototype with a 4130 tubular 26" fork made by Cook Bros based on sketch Donny provided

1978



Mert Lawwill & Terry Knight consider making BMX frames but Don Koski convinces them to make 26" mountain bike (later called Pro Cruiser)

By 1978 LAWVILL KNIGHT weremanufacturing and selling complete mountain bikes sold as Pro Cruiser making batches of 50 at a time